

USER MANUAL

MIMESIS EXCELLENCE
Digital / Analogue Preamplifier

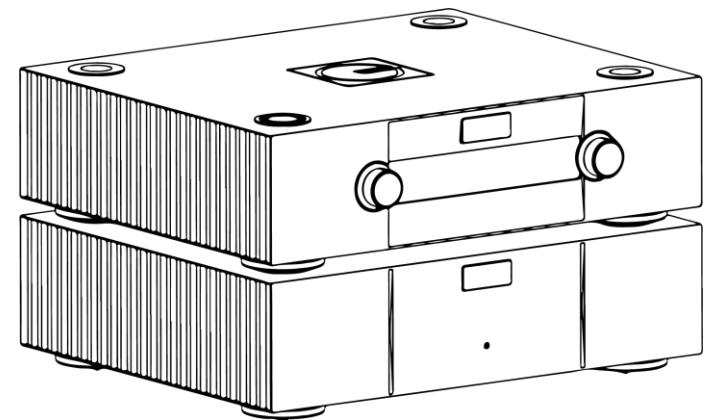

Thank you for purchasing the Goldmund MIMESIS EXCELLENCE Preamplifier.

You have acquired one of the best preamplifiers ever crafted for professional and domestic uses. Please allocate some time to peruse this manual and you shall discover invaluable insights to elevate your auditory enjoyment of the MIMESIS EXCELLENCE to unprecedented heights.

INTRODUCTION

MIMESIS EXCELLENCE Digital / Analogue Preamplifier

Goldmund was founded in 1978 and has ever since been dedicated to the accurate reproduction of sound and image.

Since 1978, Goldmund has been dedicated to developing audio equipment of the highest quality and accuracy to immerse you in the most realistic audio experience possible.

At Goldmund, we are committed to being at the forefront of the creation, development, and manufacture of the industry's most advanced technologies, including audio systems and music distribution.

Our aim is to provide the most accurate sound possible, with the least possible loss of quality during the various stages. With a team of rigorous engineers, Goldmund is constantly pushing back the boundaries of the exceptional to keep developing its own ever more innovative technology.

W A R N I N G !

This high-quality preamplifier possesses new technical features such as ultra-high band width and computer linking which are necessary for accurate transcription within today's best audio systems.

Only careful use can provide the satisfaction you are expecting from this product.

All handling must be performed according to the following instructions to avoid impairing the preamplifier's performance.

Nevertheless, if the instructions are carried out in full, you will notice that the use of the MIMESIS EXCELLENCE is quite simple and convenient.

IMPORTANT

PLEASE DO NOT CONNECT ANY CABLES OR MOVE ANY PARTS BEFORE READING THE FOLLOWING INSTRUCTIONS.

TABLE OF CONTENTS

1	PRELIMINARIES	5
2	UNPACKING	5
3	CHOICE OF LOCATION & COOLING	6
4	POWER SUPPLY	6
5	LINE VOLTAGE ADJUSTMENTS	7
6	CONNECTIONS	8
7	CONTROLS & USE	9
8	SOUND QUALITY OPTIMIZATION	11
9	SAFETY FEATURES & MAINTENANCE	11
10	TECHNICAL SPECIFICATIONS	12

1

PRELIMINARIES

For exacting technicians, musicians, and all high-fidelity music purists who demand the very best in reproduction, we strongly recommend the use of top quality power amplifiers, since most of the audio signal integrity delivered by the preamplifier can be destroyed by using lower quality amplifiers. For perfect amplification, Goldmund recommends the Goldmund Telos series of power amplifiers.

The connection between the digital and analogue sources and the preamplifier as well as between the preamplifier and the power amplifiers, holds paramount importance. Ultra-low reflection interconnect cables are absolutely mandatory to retain the time integrity that the preamplifier is designed to provide.

2

UNPACKING

You will find the following items within the custom packaging:

- The MIMESIS EXCELLENCE Preamplifier Unit
- The MIMESIS EXCELLENCE Power Supply Unit
- Preamplifier to Power Supply cable
- The remote control and batteries
- Power Cord
- User manual

Please unpack the components with care.

CAUTION

Should you need to return the MIMESIS EXCELLENCE to the factory or your local representative for warranty repair, please be aware that it must be repacked using the original packaging. This packaging has been designed to specifically safeguard your MIMESIS EXCELLENCE during transit. Utilizing alternative packaging is likely to result in damage and invalidate warranty coverage.

3

CHOICE OF LOCATION & COOLING

The Goldmund MIMESIS EXCELLENCE preamplifier generates significant heat. To ensure optimal performance and reliability, adequate cooling is essential. Avoid placing the preamplifier in poorly ventilated areas and do not place temperature-sensitive equipment on top or nearby. The power supply also generates heat, so please adhere to the ventilation guidelines provided.

The power unit is designed to minimize transformer-induced vibrations that could affect the audio circuitry. Therefore, the power supply unit is physically isolated from the preamplifier and connected by a 150 mm cable. It is recommended to position the power supply and preamplifier as far apart as the cable length allows.

The preamplifier should ideally not be placed above the power supply. Moreover, the power supply should never be positioned above the preamplifier to prevent transformer vibrations from affecting the audio circuits.

4

POWER SUPPLY

The main POWER switch is located on the rear panel of the MIMESIS EXCELLENCE power supply unit. For regular use, keep this switch permanently ON, and use the STANDBY ON/OFF function to activate or deactivate the preamplifier circuits.

When the POWER switch is turned ON, the preamplifier will become operational after a brief delay, ensuring proper stabilization of all circuitry and preventing unwanted noise.

4

POWER SUPPLY (Ctd.)

To power off the preamplifier, switch the POWER switch to the OFF position. A special safety circuit will automatically mute the preamplifier, preventing any disturbances from reaching the power amplifier and speakers, even if the preamplifier is accidentally disconnected from the mains supply. However, to optimize sound quality and ensure reliability, keep the MIMESIS EXCELLENCE continuously powered ON, managing deactivation through the Standby function.

5

LINE VOLTAGE ADJUSTMENTS

! WARNING !

If the provided line voltage is not suitable, please consult your dealer.

ATTENTION

For the 230V version, the MIMESIS EXCELLENCE operates correctly with a main line voltage of 230V \pm 10%. For the 115V version, the main line voltage must be 115V \pm 10%. If your main line voltage typically falls outside these tolerances, please contact your GOLDMUND dealer.

Check the main line fuses located on the rear panel of the unit. Use 3.15A slow-blow fuses for 115V and 1.6A fuses for 230V.

! WARNING !

Always ensure the fuse cover is fitted. Fuses are for fire prevention and do not protect against the risk of electric shock.

6

CONNECTIONS

! WARNING !

A plug with exposed connectors is hazardous if it contacts a live socket. This appliance must be earthed. Connect the non-rewireable power cord to the rear of the power supply, then plug it into the nearest wall socket. For safety and noise reduction, use only a 3-prong grounded plug.

Replacement mains leads are available from your Goldmund dealer. To achieve the best sound quality, avoid using multiple plugs or extension cords.

! WARNING !

Always handle the cable by the connectors. Never twist the cable excessively or attempt to connect or disconnect it by handling the cable body instead of the connector.

Connect the power supply output cable to the preamplifier input labeled "Power."

! WARNING !

The next step in setting up your MIMESIS EXCELLENCE is to connect your source devices, power amplifiers, and other peripherals.

Before proceeding, ensure all devices are disconnected from mains power. Connect the preamp analog output interconnects to the power amplifier using the RCA female sockets labeled "analogue outputs." Connect input cables from source devices to one of the 10 available inputs.

7

CONTROLS & USE

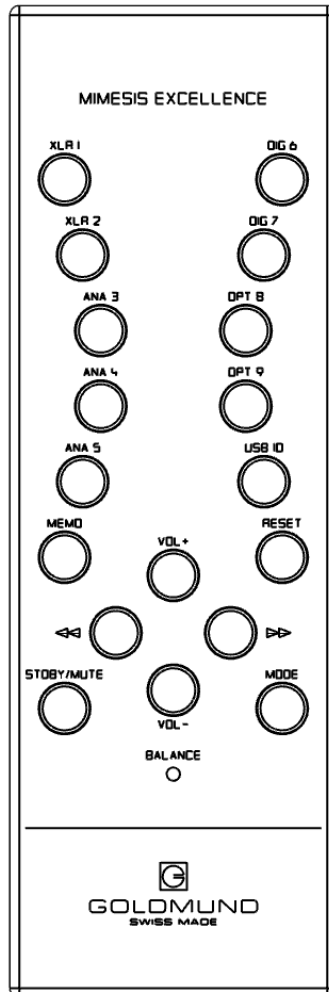

The MIMESIS EXCELLENCE is designed to capture, control, shape, and nurture fragile source inputs, allowing for volume and balance adjustments to deliver your desired output signal. The primary control functions are outlined below.

STANDBY

To activate standby mode, long press the “STDBY/MUTE” key on the remote control or short press both front panel knobs simultaneously. The front green LED will turn off and an orange LED will blink briefly.

INPUT SELECTION

The right rotary selector knob allows you to choose from ten available inputs (5 analogue and 5 digital). Each clockwise step selects the next input in the sequence. Alternatively, you can make selections using the remote control by pressing the corresponding key for the input. An orange locking LED will turn on when a valid audio signal is connected to any of the inputs.

VOLUME ADJUSTMENT

You can adjust the volume manually using the right knob on the front panel of the device or by using the “VOL +” and “VOL -” keys on the remote control.

VOLUME MEMORY / RESET

This function allows you to save your preferred volume setting.

To memorize the volume using the front panel of the preamplifier, select the desired volume, and then long-press the right knob until the inputs and volume displays blink twice. To reset to the memorized volume, short-press the right knob.

To memorize the volume using the remote control, select your desired volume and press the “MEMO” key. To reset to the memorized volume, press the “RESET” button.

7

CONTROLS & USE (Ctd.)

BALANCE ADJUSTMENT

To adjust the balance of the preamplifier using the front panel, long-press the left knob until the letter C (center), R (right), or L (left) appear on the screen. If the balance is set at 50, the letter C will be displayed. If the balance is greater than 50, the letter R will appear. If the balance is less than 50, the letter L will be displayed. Use the right knob to fine-tune the balance. Rotating the right knob clockwise adjusts the balance to the right, and the R letter will appear on the screen. Rotating the right knob counterclockwise adjusts the balance to the left, and the L letter will be displayed. A dot in the front panel on inputs and volume displays indicate the left and right balance of the audio signal respectively. The dot will not appear if the balance is centered.

To adjust the balance of the preamplifier using the remote control, press the "MODE" key. The balance LED will turn on, then use the keys located near the volume controls. The left button adjusts the balance to the left, and the right button adjusts it to the right. To reset the balance, press both of these buttons simultaneously.

MUTE

To mute the preamplifier's output, short press the "STDBY/MUTE" key on the remote control or short-press the left knob on the front panel. To return the preamplifier to its normal operation, press either the key or the left knob again, and it will resume at the same volume setting as before engaging the mute function.

USB-C PORT

Control of the MIMESIS EXCELLENCE preamplifier can be achieved through a conventional computer USB-C port. For additional details, kindly reach out to your Goldmund representative.

8

SOUND QUALITY OPTIMIZATION

WARM-UP SONIC EFFECT

If the preamplifier has been unpowered for an extended period, optimal sound quality may only be attained after several hours of operation. The critical circuits must warm up to approximately +55°C (+131°F) to achieve their best performance. Therefore, Goldmund recommends keeping the MIMESIS EXCELLENCE powered on continuously.

GOLDMUND "MECHANICAL GROUNDING"

To maximize the performance of the Goldmund MIMESIS EXCELLENCE preamplifier, Goldmund employs its renowned construction method to eliminate vibrations. For optimal results, place the MIMESIS EXCELLENCE on a very rigid support directly coupled to the ground. Avoid using any decoupling materials. If placing the preamplifier on carpet, use pin-point supports to ensure the unit is firmly coupled to the floor.

9

SAFETY FEATURES & MAINTENANCE

MAINTENANCE

To clean your MIMESIS EXCELLENCE, use only a soft, clean, dry, or slightly damp cloth. Avoid using domestic cleaning products.

! WARNING !

Always turn the power off before cleaning your preamplifier.

For all inquiries related to product servicing and operation, please contact your local authorized Goldmund dealer.

TECHNICAL SPECIFICATIONS

INPUTS

- Input impedance: 51 kOhms
- Maximum input level (balanced): 19.2 Vrms
- Maximum input level (unbalanced): 10.3 Vrms

OUTPUTS

- Output impedance: 75 Ohms
- Maximum output level (balanced): 20 Vrms
- Maximum output level (unbalanced): 10 Vrms

FREQUENCY RESPONSE

Values for any level to maximum output level:

- +/- 0 dB, 20 – 20 kHz
- +/- 3 dB, 0.2 – 530 kHz

DISTORTION

With 1 Vrms output level, 80 KHz measurement bandwidth, 600 ohms termination impedance:

- THD unbalanced input to unbalanced output: 0.0006 % flat with frequency
- THD balanced input to balanced out: 0.0004 % flat with frequency
- THD unbalanced digital input to unbalanced output: 0.00085 % (-6dBFS) flat with frequency

SPEED

- Slew rate of the amplification stages: 15 V/us

CROSSTALK

- Separation: > 85 dB between channels (20 Hz – 20 kHz)

TECHNICAL SPECIFICATIONS (Ctd.)

NOISE

- Signal-to noise ratio on line input: > 130 dB (0.01 Hz - 10 Mhz)
- Weighted ASA A: > 140 dB

OPERATING TEMPERATURE

- Room temperature: -30 to +40 degrees Celsius
- Internal temperature: +45 to +70 degrees Celsius

POWER

- Nominal line voltage: 115 or 230 V
- Input voltage range: +/-15 %
- Maximum power consumption: 20 W

GROUNDING

- Separated ground and earth signal.

FRONT PANEL CONTROLS

- VOLUME control
- BALANCE control
- MUTE & STANDBY control
- VOLUME MEMO control

TECHNICAL SPECIFICATIONS (Ctd.)

REAR PANEL CONNECTORS & CONTROLS

- Power connector
- 3x pairs of analogue RCA input connector (right and left)
- 2x pairs of analogue XLR input connector (right and left)
- 2x S/PDIF digital RCA input connector
- 2x Optical digital RCA input connector
- 2x pair of RCA output connector (right and left)
- 2x pair of XLR output connector (right and left)

POWER SUPPLY CONTROLS

- Power cord socket (3 lugs)
- Fuse 3.15A for 115V & Fuse 1.6A for 230V
- Voltage selector 115/230 V
- Earthing post (yellow-green)

SIZE & WEIGHT

Preamplifier (without power cord):

- 44 W x 12.9 H x 39.3 D (cm)
- 17.3 W x 4.7 H x 15.3 D (inch)
- 11.5 Kg

Power Supply (without power cord):

- 44 W x 12.9 H x 38.6 D (cm)
- 17.3 W x 4.7 H x 15.9 D (inch)
- 13 Kg

Information and product specifications contained in this manual are subject to change without prior notice.

Visit our website at www.goldmund.com